

**Spare parts list**

**Edition 20111011**



**Valid for serial no. 001-xxx-xxxx**

**Ordering no. Product**

- 0558 003 179 Powercut™ 650, 208/230V
- 0558 003 180 Powercut™ 650, 208/230V 25ft
- 0558 003 515 Powercut™ 650, 208/230V BL
- 0558 005 328 Powercut™ 650, 460V

Spare parts are to be ordered through the nearest ESAB agency. Kindly indicate type of unit, serial number, denominations and ordering numbers according to the spare parts list.

Maintenance and repair work should be performed by an experienced person, and electrical work only by a trained electrician. Use only recommended spare parts.

Rights reserved to alter specifications without notice.

**Powercut™ 650**

Item	Qty 208/ 230V	Qty 208/ 230V BL	Qty 460V	Ordering no.	Denomination	Notes
101	1	1	1	0558 001 922	Plasma tube top cover	16"
102					Label ESAB	
103	2	2	2	0558 001 916	Plasma tube end cover	
104					Label customer assistance	
105					Label pattend power supplies	
106					Label warning	
107	1	1	1	0558 001 918	Plasma tube bottom cover	16"
108	2	2	2	0558 001 926	Plasma tube side cover	16"
109					Label warning	
110	1	1		0558 003 360	Cable input power	PT31 XLPC 40A BL
110			1	0559 000 034	Cable input power	
111	1	1	1	0559 000 026	LBL breakdown	
112					Label caution read manual	
113					Label fault indicator (BL)	
114					Label warning	
115					Label	208/230V AC
116					Label- high voltage	

# Powercut™ 650

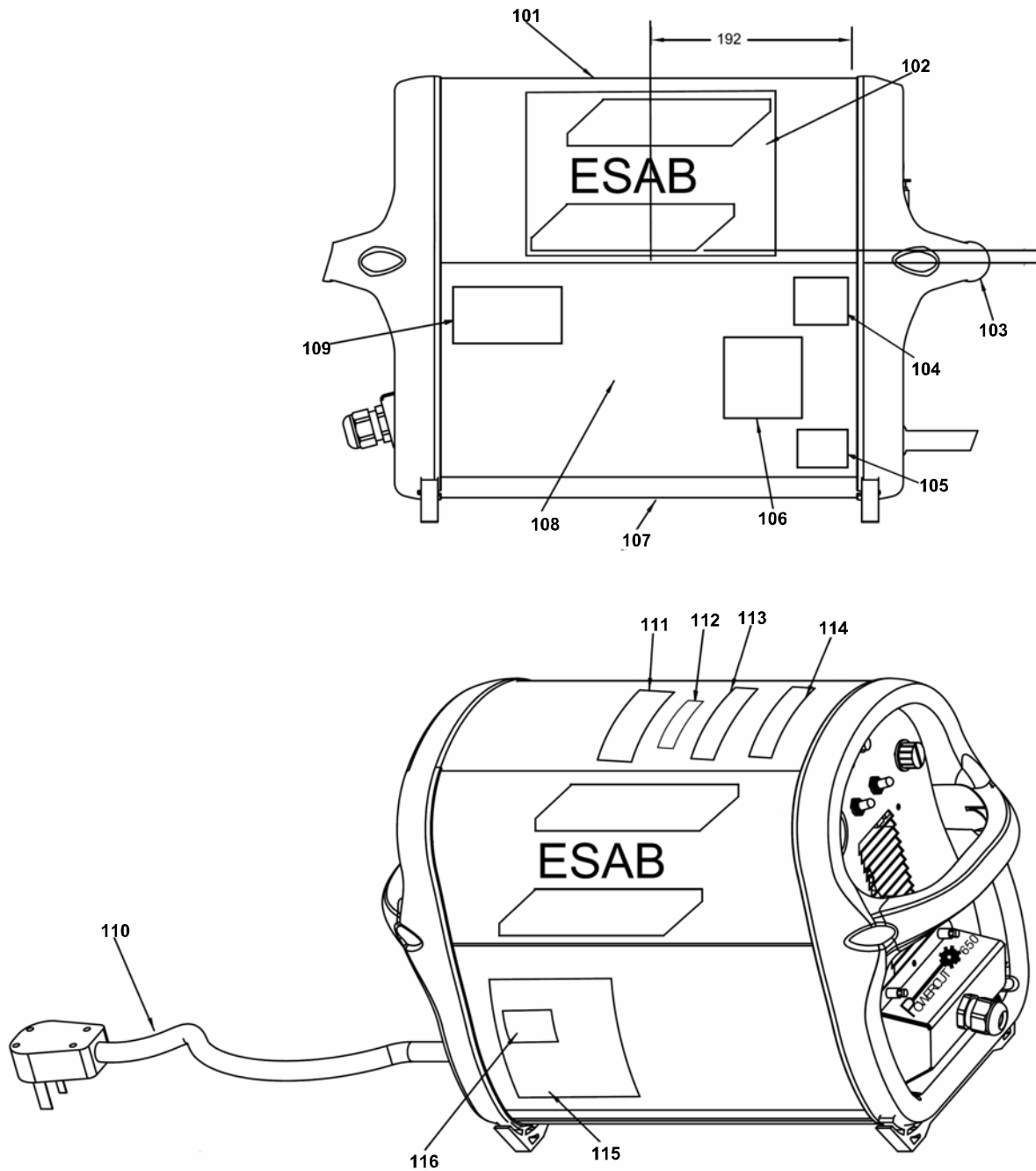

C = component designation in the circuit diagram

Item	Qty 208/ 230V	Qty 208/ 230V BL	Qty 460V	Ordering no.	Denomination	Notes	C
201	3	3	3	0559 000 150	Connector male	1/8 NPTM	
201	2	2	2	0558 006 261	Elbow union	90 DEG 1/8 NPT	
201	1	1	1	0558 000 594	Gauge pressure		
201	2	2	2	0558 000 593	Grommet	Rubber 1.50 ID 1.75 GD X .06W	
202	2	2	2	0558 000 596	Switch seal		
203	1	1	1	0558 000 385	Switch	LPG 50/80 PCM	S1
204	1	1	1	0558 000 384	Lamp white	125V	PL1
205	1	1	1	0004 487 025	Lamp LED yellow	12V	PL2
206	1	1	1	0558 000 698	Switch	LPG 80	S2
207	1	1	1	0558 001 176	Potentiometer	10K 3W	R1
207	1	1	1	0558 001 388	Knob	1.17 DIA 1/4" Shaft	
208	1		1	0558 003 086	Plasma tube panel front		
208		1		0558 005 339	Plasma tube panel front		
209					Label PC-650		
210	1	1	1	0558 002 581	Strain relief input	NPT1	
210	1	1	1	0558 004 266	Strain relief NUT	1"	
211	1	1	1	0558 000 396	PC board shunt		PCB4
211	2	2	2	0559 000 213	Capacitor	47nF 600V	C23, C23A
212	2	2	2	0558 003 312	Cover KYDEX PC-650		
213	4	4	4	0558 001 930	Plasma tube extruded bar	16"	
214	1		1	0558 003 307	Torch compartment cover		
214		1		0558 005 498	Torch compartment cover		
215	2	2	2	0558 002 780	Foot plasma tube		
216	1	1	1	0559 000 120	Strain relief, (WORK cable)		
216	1	1	1	0558 000 608	Cable WORK/GND		

**Powercut™ 650**

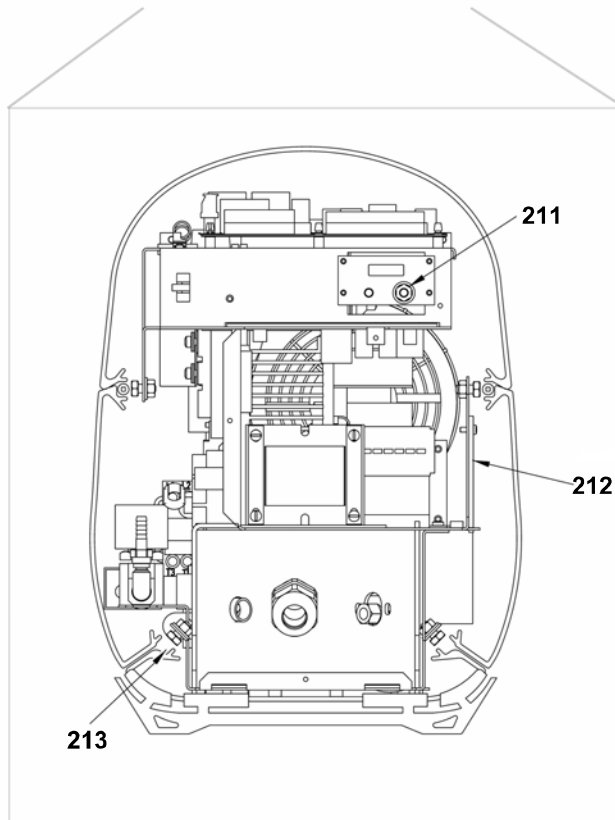
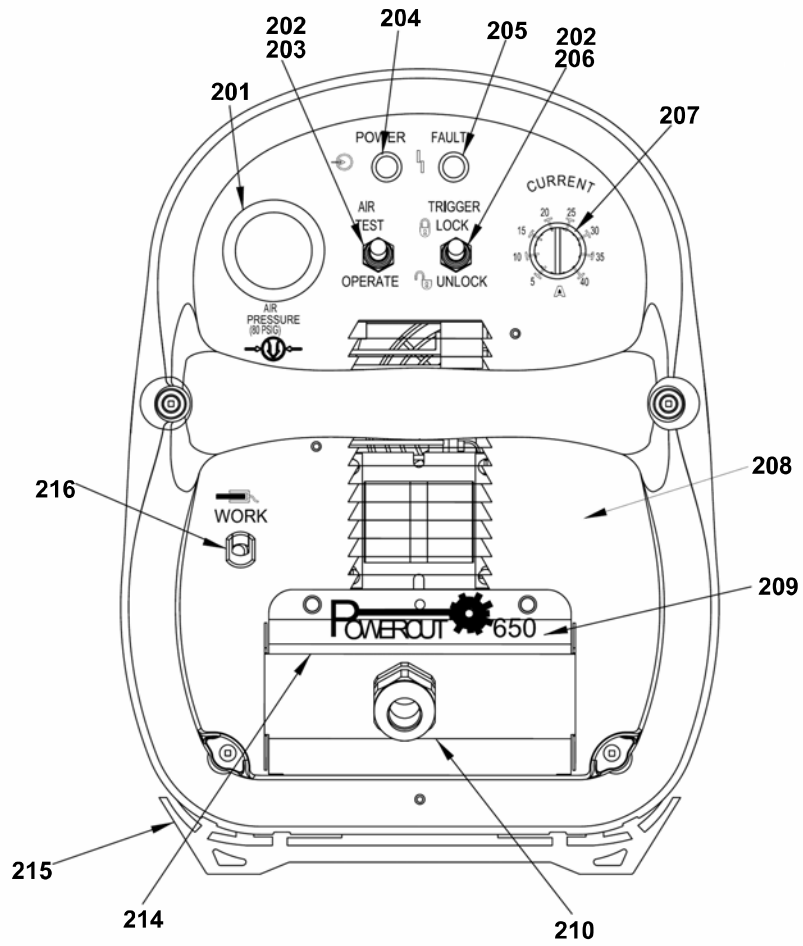

C = component designation in the circuit diagram

Item	Qty 208/ 230V	Qty 208/ 230V BL	Qty 460V	Ordering no.	Denomination	Notes	C
301	1	1	1	0558 005 659	Finger guard		
302	1	1		0558 004 125	Power switch		S3
302			1	0558 005 434	Power switch		S3
303					Label 208/230Volt unit		
304					Label LR-30071		
305					Name plate code serial stock		
306	1		1	0558 003 306	Rear panel		
306		1		0558 005 340	Rear panel		

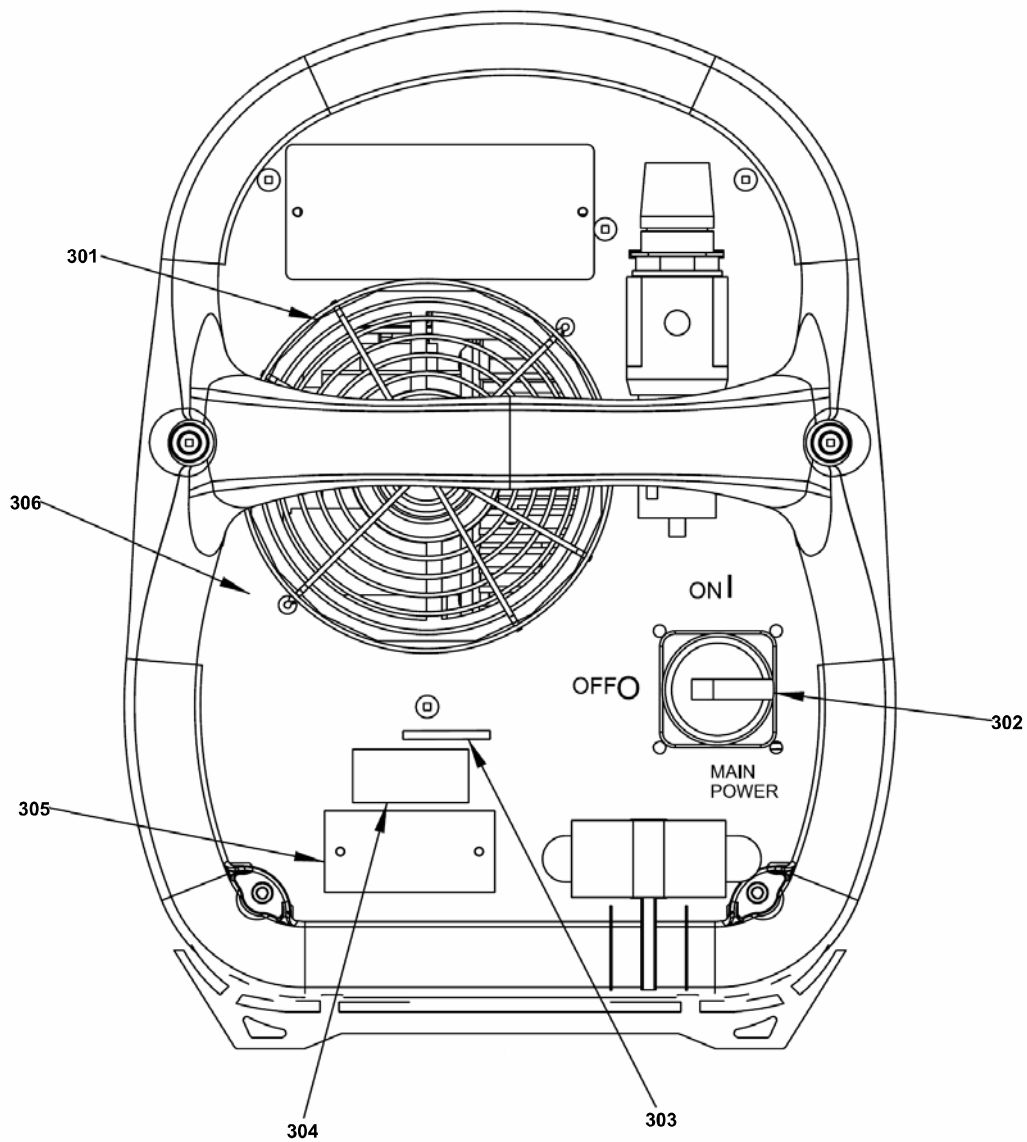



C = component designation in the circuit diagram

Item	Qty 208/ 230V	Qty 208/ 230V BL	Qty 460V	Ordering no.	Denomination	Notes	C
401	1	1	1	0558 003 313	Partition torch plumb		
402					Label warning electrical shock		
402					Label high voltage		
403	0.9	0.9	0.9	0558 005 436	Tubing		
404	1	1	1	0558 000 755	Term bushing		
405	1	1	1	0559 000 159	Connector male	1/4 NPTM	
406	1	1	1	0558 006 156	Valve	SOL1 24VAC	SOL1
406	1	1	1	0559 000 089	NPL pipe	1/4 X.38 L BRS	
406	1	1	1	0559 000 003	Tee street	1/8-27 NPT	
406	2	2	2	0559 000 151	Elbow male swivel	90DEG 1/4	
406	1	1	1	0559 000 253	Flow switch		FS
406				0004 492 009	Adaptor hose gland		
406	1	1	1	0558 006 271	Bushing brass		
407					Label ground	1/8" - 1/4"	
408	1	1	1	0558 003 308	Base	Aluminium	
409	1	1		0558 005 437	Inductor power factor correct		L2
409				0559 000 230	Line reactor	3ph	L2
409			1	0559 000 229	Line reactor	3ph	L2
410	1	1	1	0559 000 228	Transformer high voltage		T5
411	1	1	1	0558 002 183	Cover high freo KYDEX		
412	1	1	1	0558 001 180	Spark gap assembly		SG
413	3	3	3	0559 000 150	Connector male	1/8 NPTM	
414	2	2	2	0558 006 261	Elbow union	90DEG 1/8 NPT	
415	1	1	1	0558 005 159	Adapter	A/I-GF	



# Powercut™ 650

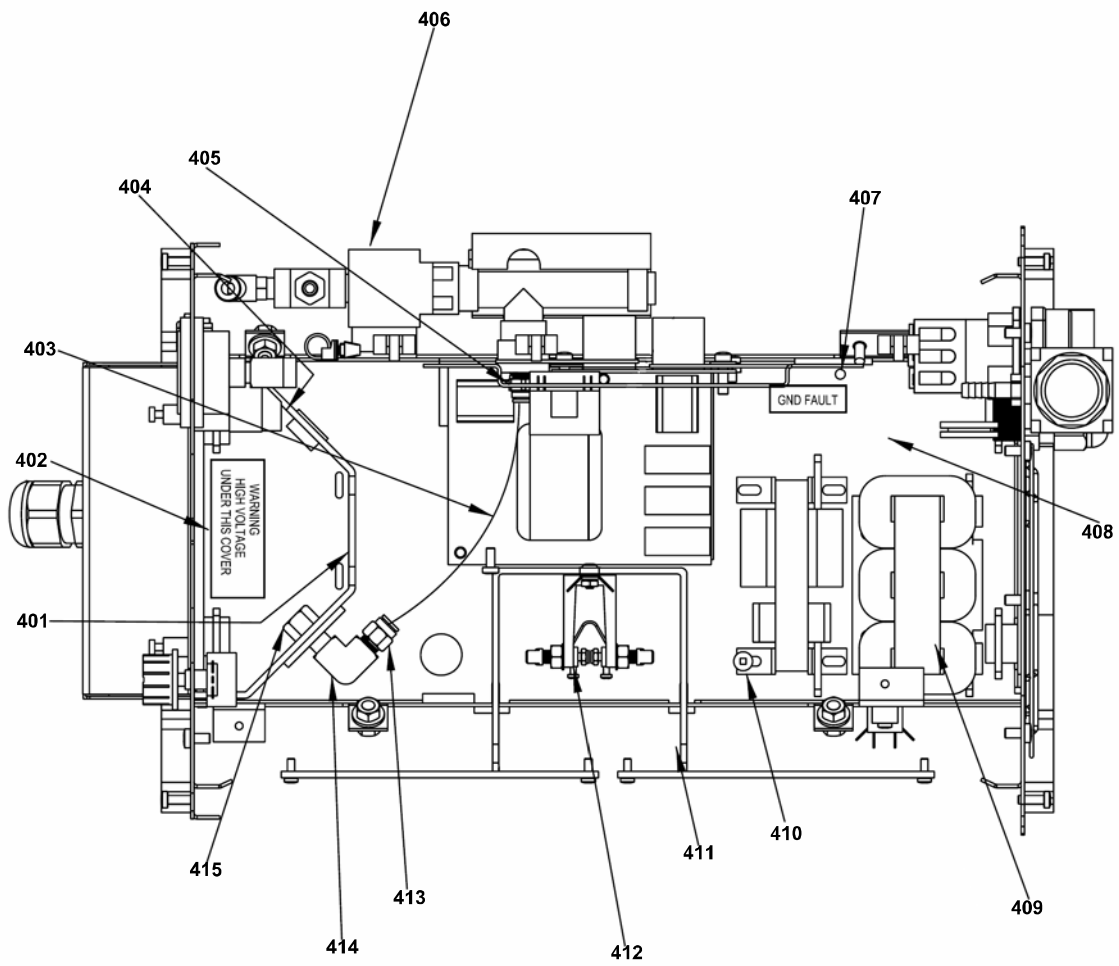

C = component designation in the circuit diagram

Item	Qty 208/ 230V	Qty 208/ 230V BL	Qty 460V	Ordering no.	Denomination	Notes	C
501	4	4	4	0558 000 584	Grommet		
502	1	1	1	0558 005 158	PCB universal control		PCB1
503	1	1	1	0558 003 785	PCB start up network		PCB5
504	1	1		0558 003 304	Kit wire main	208/230V	
504			1	0558 005 316	Kit wire main	400/460V	
504	1	1		0558 003 305	Kit wire	208/230V	
504			1	0558 005 317	Kit wire	400/460V	
505	1	1	1	0559 000 028	Grommet	Rubber 0.44 ID 0.56 GD X .06W	
506	1	1	1	0558 003 311	Bracket control board	MTG	
507	2	2	2	0558 000 593	Grommet	Rubber 1.50 ID 1.75 GD X .06W	

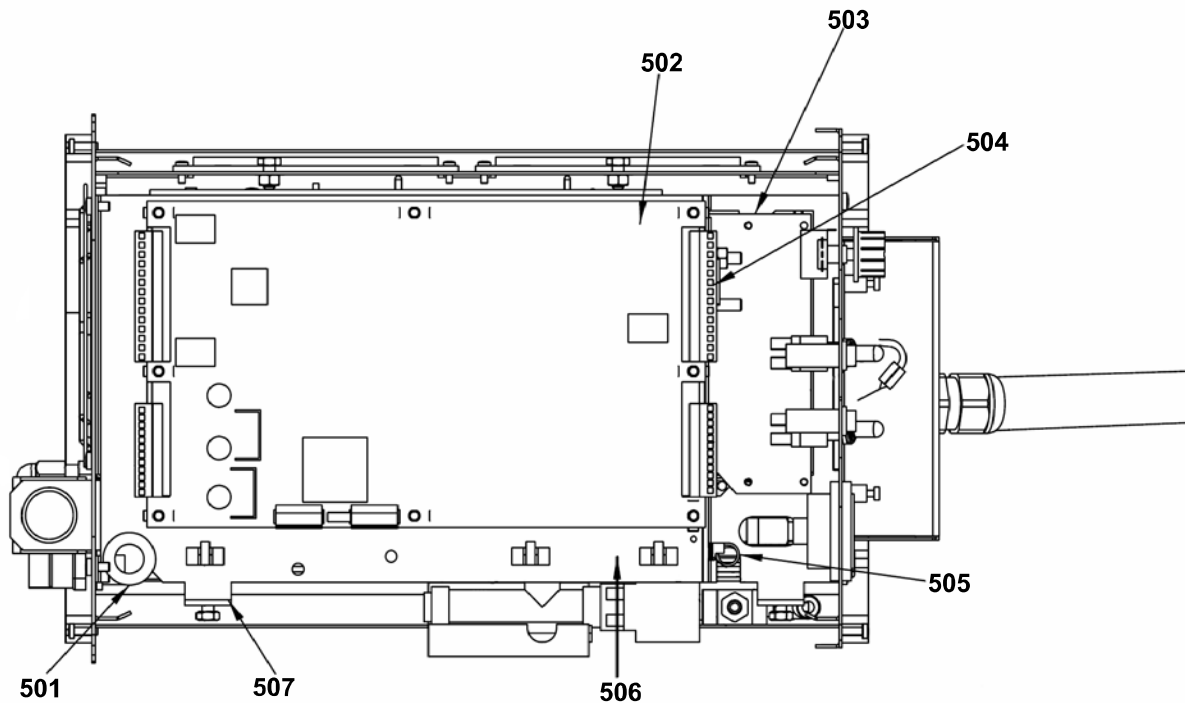

# Powercut™ 650

Item	Qty 208/ 230V	Qty 208/ 230V BL	Qty 460V	Ordering no.	Denomination	Notes
601	4	4	1	0559 000 094	Bushing snap	
602	1	1	1	0559 000 086	Heyco snap bushing	

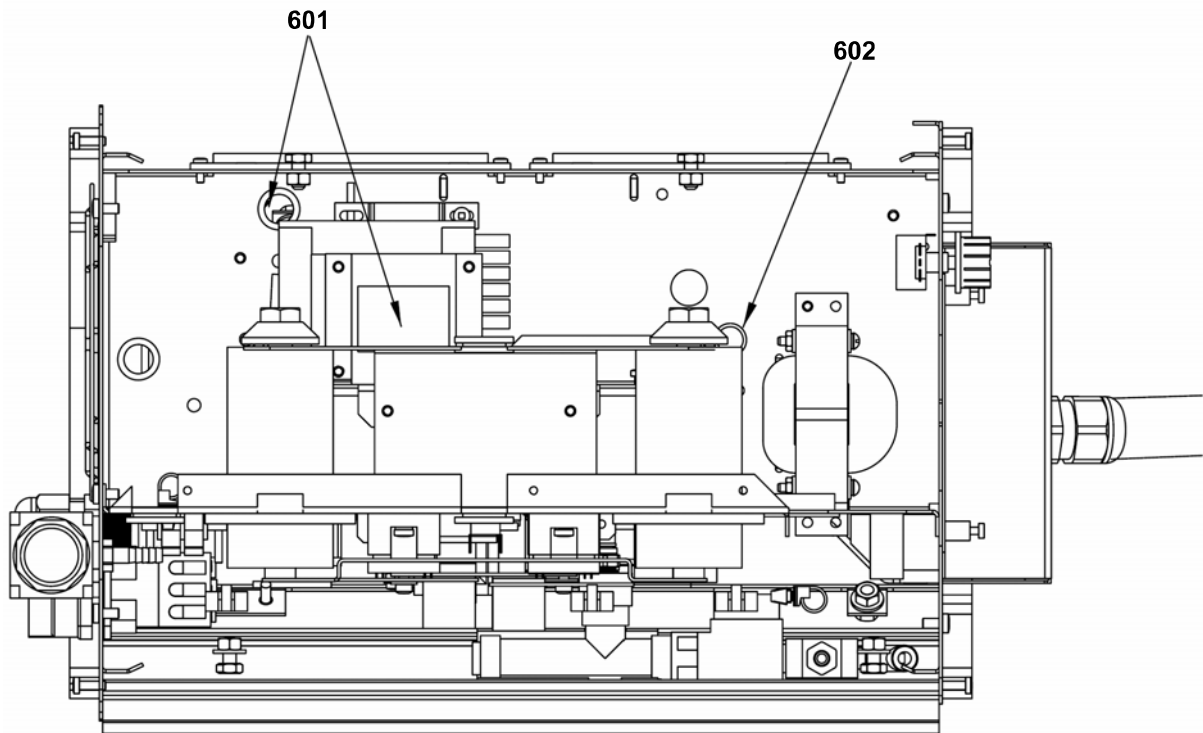

**C = component designation in the circuit diagram**

Item	Qty 208/ 230V	Qty 208/ 230V BL	Qty 460V	Ordering no.	Denomination	Notes	C
701	2	2		0559 000 217	Resistor	2x50kOHM 12W	(R2,R15), (R16,R17)
701			2	0559 000 214	Resistor 10k, Capacitor 1uF		(R2,C3), R15,C15)
702	1	1		0559 000 209	Capacitor	1uF 630VAC	C3
703	2	2	2	0558 000 788	Grommet		
703	2	2	2	0558 000 615	Capacitor	1000uF 400VDC	C1,C2
704	2	2		0559 000 016	Busbar IGBT		
704			1	0559 000 017	Busbar IGBT		
704	2	2		0004 487 114	Capacitor	1.0uF 600VDC	C15,C16
704			1	0558 005 444	Capacitor	0.5uF 1200VDC	C22
705	4	4	4	0558 000 584	Grommet		
706	2	2		0558 005 445	Module IGBT	Use with item 750	Q1,Q2
706			1	0558 005 462	Module IGBT	Use with item 750	Q1
706	2	2		0558 001 177	PC board IGBT driver		PCB2/PCB3
706			1	0558 001 178	PC board IGBT driver		PCB3
707	1	1	1	0558 000 594	Gauge pressure		
707	2	2	2	0558 000 593	Grommet	Rubber 1.50 ID 1.75 GD X .06W	
707	0.9	0.9	0.9	0558 005 436	Tubing		
707	2	2	2	0558 006 261	Elbow union	90DEG 1/8 NPT	
707	3	3	3	0559 000 150	Connector male	1/8 NPTM	
708	1	1	1	0558 000 614	Heatsink		
709	1	1	1	0559 000 074	Bushing snap		
710	5	5	5	0559 000 212	Capacitor	0.01uF 1kV	C5,6,7,8,10

**SPARE PARTS SETS**

Item	Ordering no.	Denomination	Notes
750	0192 058 101	Thermal compound	Use with item 751 to spread paste
751	0458 910 001	Roller	Use with item 752
752	0458 910 002	Roller handle	

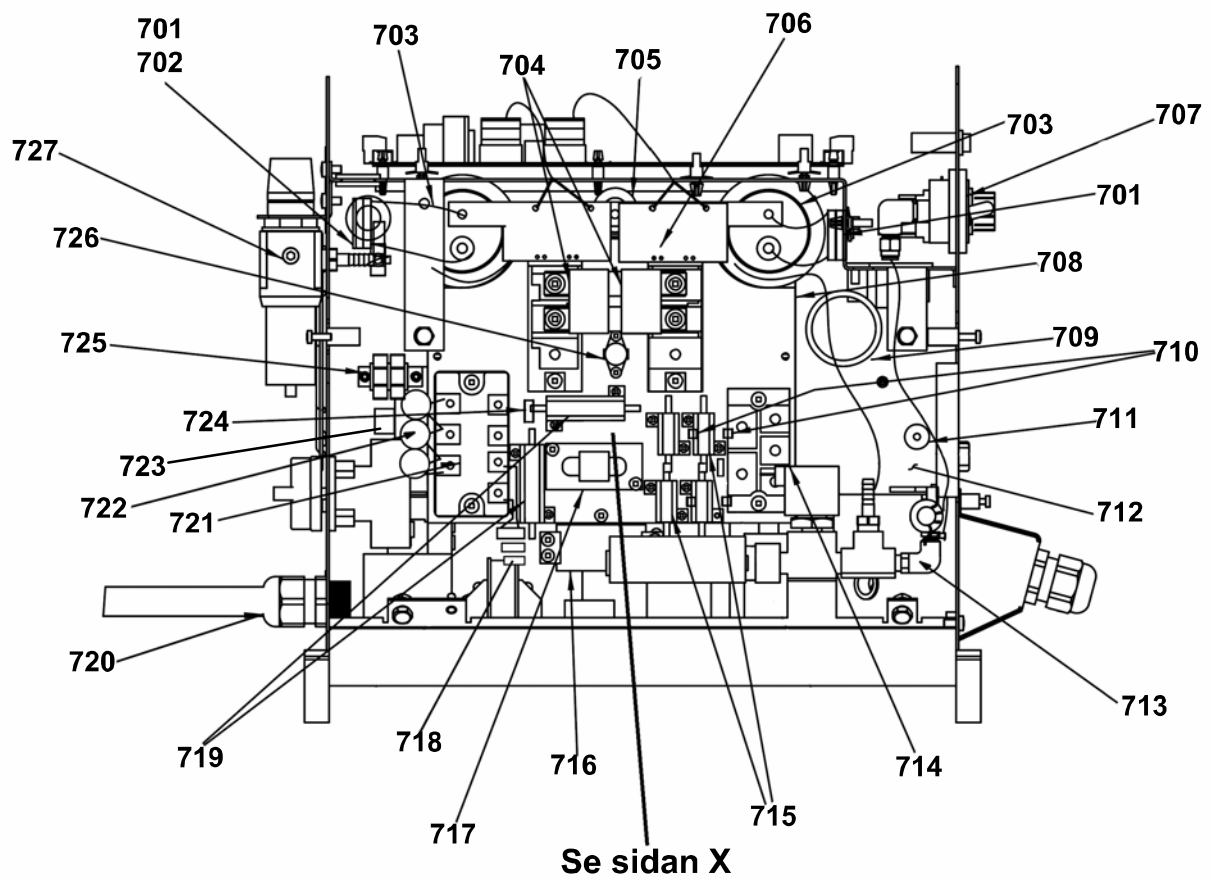

**Powercut™ 650**

Item	Qty 208/ 230V	Qty 208/ 230V BL	Qty 460V	Ordering no.	Denomination	Notes	C
711	1	1	1	0558 005 442	Standoff insulating	Nylon	
712	1	1	1	0558 003 309	Heatsink bracket		
713	1	1	1	0559 000 106	Elbow male swivel	90DEG 1/8 NPTM	
714	1	1	1	0558 000 626	Module output bridge	60A 600V, Use with item 750	D1
715	4	4	4	0558 000 404	Resistor	20OHM 25W, Use with item 750	R3,4,5,6
716	1	1	1	0558 000 469	Cap met poly		C4
716	1	1	1	0559 000 219	Resistor	39kOHM 2W	R9
717	1	1	1	0004 487 078	Transformer assy current		T4
718			2	0559 000 117	Core saturable		
719	2	2	2	0558 000 400	Resistor	50W 10OHM, Use with item 750	R7,R10
720	1	1		0558 003 360	Cable input power		
720			1	0559 000 034	Cable input power		
720	1	1	1	0558 003 353	Strain relief input	NPT 3/4	
720	1	1	1	0349 312 878	Strain relief NUT	3/4"	
721	1	1	1	0558 000 623	Module input bridge	Use with item 750	IBR
722			1	0559 000 221	Varistor	3x510V	(MOV1,2,3)
723	1	1		0559 000 224	Varistor 275V, Capacitor 0.47uF		(MOV1,C20)
724	1	1	1	0559 000 218	Capacitor	0.22uF 1000VDC	C19
725	2	2	2	0558 000 600	Terminal block	(2 POS 20A)	TB1,TB5
726	1	1	1	0004 487 055	Switch termal	Use with item 750	TS1
727	1	1	1	0558 005 394	Filter regulator		
727				0004 492 009	Adaptor hose gland		
727	1	1	1	0559 000 076	Cap plug		
727	2	2	2	0559 000 014	Plug hole	HEX HD .25-20 X 0.50	

**SPARE PARTS SETS**

Item	Ordering no.	Denomination	Notes
750	0192 058 101	Thermal compound	Use with item 751 to spread paste
751	0458 910 001	Roller	Use with item 752
752	0458 910 002	Roller handle	

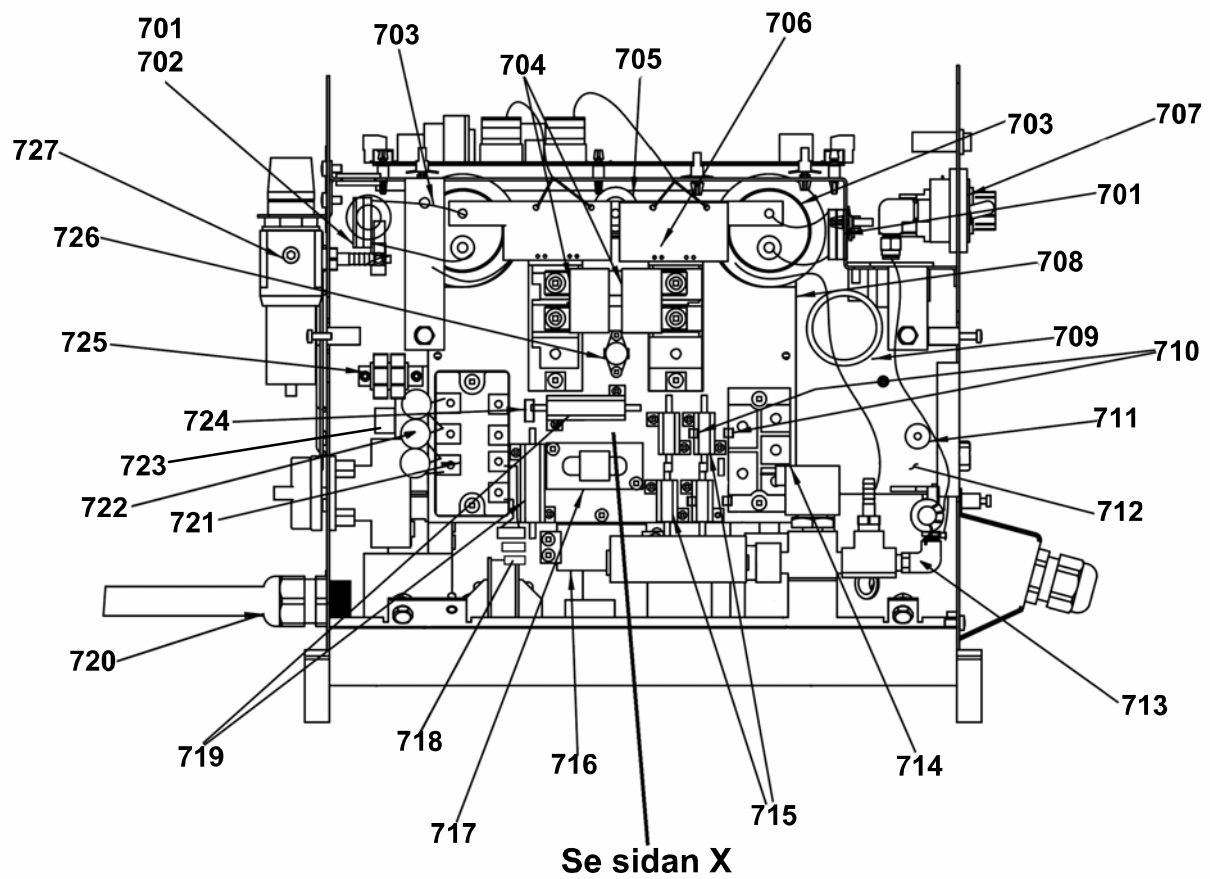

C = component designation in the circuit diagram

Item	Qty 208/ 230V	Qty 208/ 230V BL	Qty 460V	Ordering no.	Denomination	Notes	C
801	1	1	1	0558 005 439	Inductor output		L1
802	1	1	1	0558 005 438	Main transformer		T1
803	4	4	4	0558 000 584	Grommet		
804	1	1		0558 005 437	Inductor power factor correct		L2
804				0559 000 230	Line reactor	3ph	L2
804			1	0559 000 229	Line reactor	3ph	L2
805	1	1	1	0559 000 252	Fan	AC axial	M1
806			1	0559 000 255	Control transformer		T2
806	1	1		0559 000 254	Control transformer		T2
807	2	2	2	0558 000 600	Terminal block	(2 pos 20A)	TB1, TB5
807	1	1	1	0559 000 216	Capacitor	2x0.01uF 1000VDC	(C11, C12)
807	1	1	1	0559 000 223	Capacitor	0.01uF 250 VAC	C9
808	1	1	1	0558 003 310	Transformer bracket		
809	1	1	1	0559 000 206	Capacitor	2x2500pF 15kV	(C13, C14)
810	1	1	1	0558 000 403	Reactor assy high freq		T3
810	2	2	2	0559 000 160	Hole plug	Nylon	

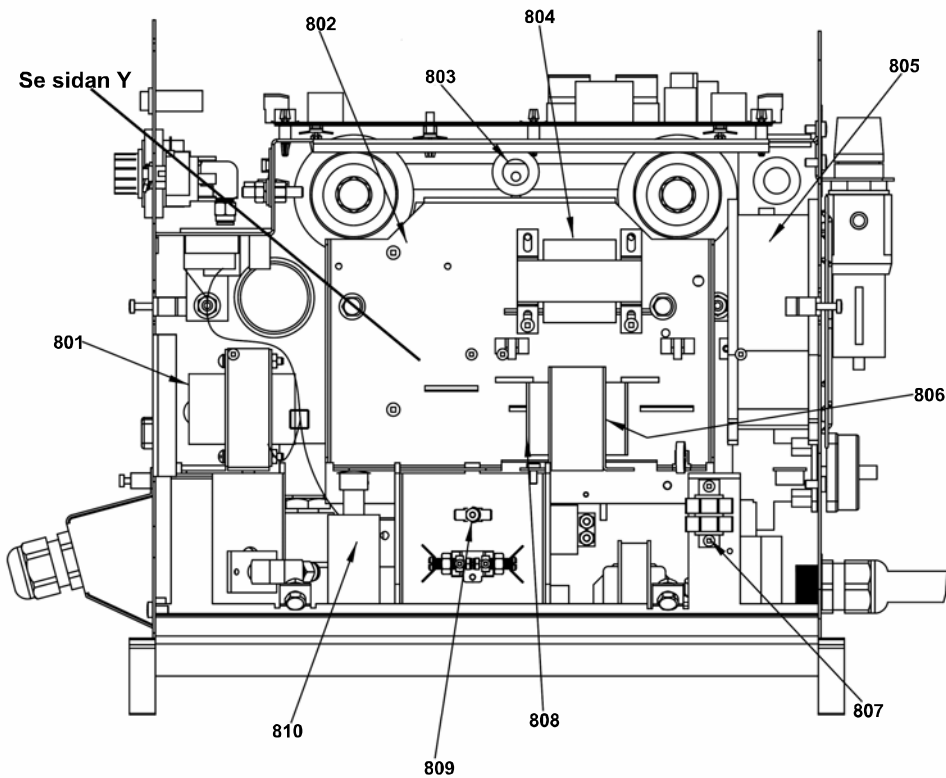



C = component designation in the circuit diagram

Item	Qty 208/ 230V	Qty 208/ 230V BL	Qty 460V	Ordering no.	Denomination	Notes	C
901	4	4	4	0558 000 584	Grommet		
902	2	2		0559 000 217	Resistor	2x50kOHM 12W	(R2,R15), (R16,R17)
902			2	0559 000 214	Resistor 10k, Capacitor 1uF		(R2,C3), (R15,C15)
903	2	2		0004 487 114	Capacitor	1.0uF 600 VDC	C15,C16
903			1	0558 005 444	Capacitor	0.5uF 1200 VDC	C22
904	2	2		0558 005 445	Module IGBT	Use with item 950	Q1,Q2
904			1	0558 005 462	Module IGBT	Use with item 950	Q1
904	2	2		0558 001 177	PC board IGBT driver		PCB2/PCB3
904			1	0558 001 178	PC board IGBT driver		PCB3
905	2	2		0559 000 016	Busbar IGBT		
905			1	0559 000 017	Busbar IGBT		
906			2	0559 000 117	Core saturable		
907			1	0559 000 221	Varistor	3x510V	(MOV1,2,3)

**SPARE PARTS SETS**

Item	Ordering no.	Denomination	Notes
950	0192 058 101	Thermal compound	Use with item 951 to spread paste
951	0458 910 001	Roller	Use with item 952
952	0458 910 002	Roller handle	

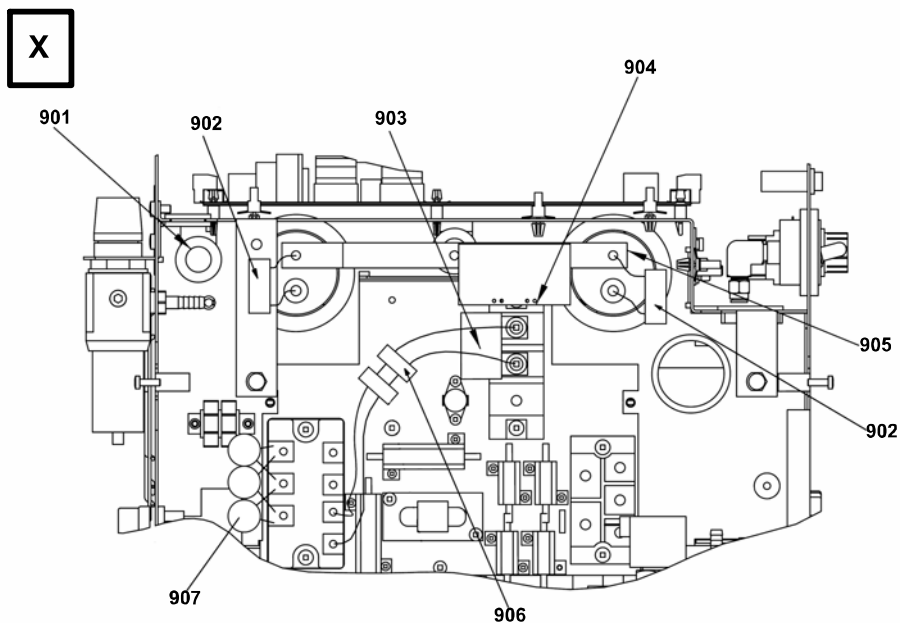

C = component designation in the circuit diagram

Item	Qty 208/ 230V	Qty 208/ 230V BL	Qty 460V	Ordering no.	Denomination	Notes	C
1001			1	0559 000 255	Control transformer		T2
1001	1	1		0559 000 254	Control transformer		T2

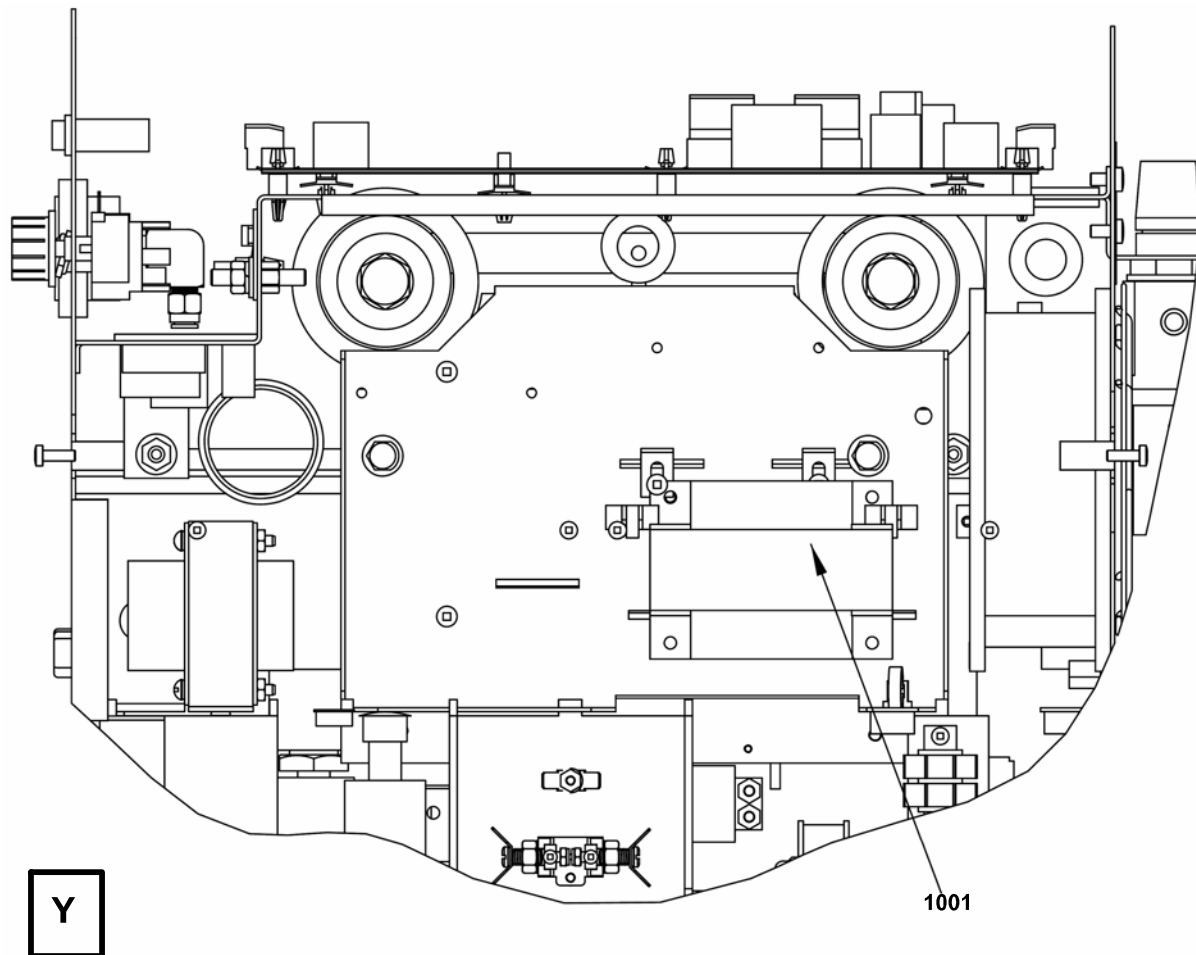

**Accessories**

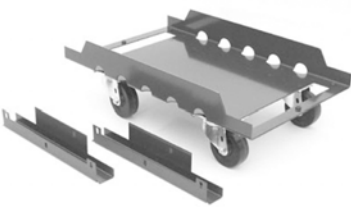
	<p><b>Torch Wrap and Spare Parts Kit Holder</b>  <b>This enables operator to store S/P Kit, wrap torch and work cable for easy transport and storage</b> ..... 0558 003 398</p>
	<p><b>Wheel Kit</b>  <b>For easy transport of system</b> ..... 0558 003 399</p>
	<p><b>Torch Guide Kits</b>  <b>The Deluxe kit includes attachments for circle and straight line cutting on ferrous and non-ferrous metals</b>  <b>Deluxe, 1 3/4"-42" (44.5mm-1,066.8mm) radius</b> . 0558 003 258  <b>Basic, 1 3/4"-28" (44.5mm-711.2mm) radius</b> .... 0558 002 675</p>
	<p><b>Plasma Flow Measuring Kit</b>  <b>This valuable troubleshooting tool allows measurement of the actual plasma gas flow through the torch</b> ..... 0558 000 739 (19765)</p>
	<p><b>Input Receptacle</b>  <b>230vac/50Amp, 3 Prong</b> ..... 674540</p>

Torch PT-31XLPC, 7.6m .....	0558 003 183
<b>PT-31XLPC Replacement torch</b> <b>Torch comes assembled with Long "CE" Heat</b> <b>Shield, Nozzle, Electrode and Swirl Baffle .....</b>	0558 005 393
Wear Part Kit PT-31XLPC .....	0558 003 301







